

SERIES W1B & W2B ACCESS COVER

TABLE OF CONTENTS

Vendor Data

Material Data Sheet

Specification

Component Parts List

Storage, Handling, Installation & Maintenance Instructions

Limited Warranty

VENDOR DATA

**HALLIDAY PRODUCTS, INC.
6401 Edgewater Drive
Orlando, FL 32810**

Phone: 407-298-4470 - Fax: 407-298-4534

Toll Free: 800-298-1027

Email: marketing@HallidayProducts.com

Web Site at www.HallidayProducts.com

Armond Bordeau, Contact

MATERIAL DATA SHEET

Access Frames and Covers

1. Door leaf shall be 3/16-in thick type 304 stainless steel diamond pattern plate, reinforced with a ¼-in. stainless steel flat bar to attain a 300 lb/ft² (1462 kg/m²) live load.
2. Frame members shall be ¼-in. thick mill finish type 304 stainless steel.
3. The following items shall be Type 316 stainless steel: hinges, hold-open arm, slam lock and all attaching hardware. The compression spring shall be Type 17-7 stainless steel
4. Units shall carry a Lifetime Guarantee against defects in material and/or workmanship.

Series W1B and W2B Access Covers

STANDARD FEATURES:

Stainless steel compression spring assist
Auto-lock, T316 stainless steel hold-open arm with release handles
T-316 stainless steel hinges and attaching hardware
T-316 stainless steel slam lock w/ removable key
Channel frame
Single or double leaf construction
300 lb/ft² (1462 kg/m²) live load
Lifetime guarantee

SPECIFICATION:

The W1B (single leaf) and W2B (double Leaf) access frames and covers as manufactured by Halliday Products, Inc. of Orlando, Florida shall have a ¼-in. thick one-piece, mill finish, type 304 stainless steel frame, incorporating concrete anchor plates 18-in. on center. A 1-½-in. drainage coupling shall be located in the front left corner of the channel frame. Door panel(s) shall be 3/16-inch stainless steel diamond plate reinforced to withstand a 300 lb/ft² (1462 kg/m²) live load. Door(s) shall open to 90 degrees and automatically lock with T-316 stainless steel hold-open arm(s) with anodized aluminum release handle(s). For ease of operation the hold-open arm shall incorporate enclosed stainless steel compression spring assists. Door(s) shall close flush with the frame. Hinges and all fastening hardware shall be T316 stainless steel. Unit shall lock with T-316 stainless steel slam lock with removable key and have a non-corrosive handle. Unit shall carry a Lifetime guarantee against defects in material and/or workmanship.



SERIES W1B

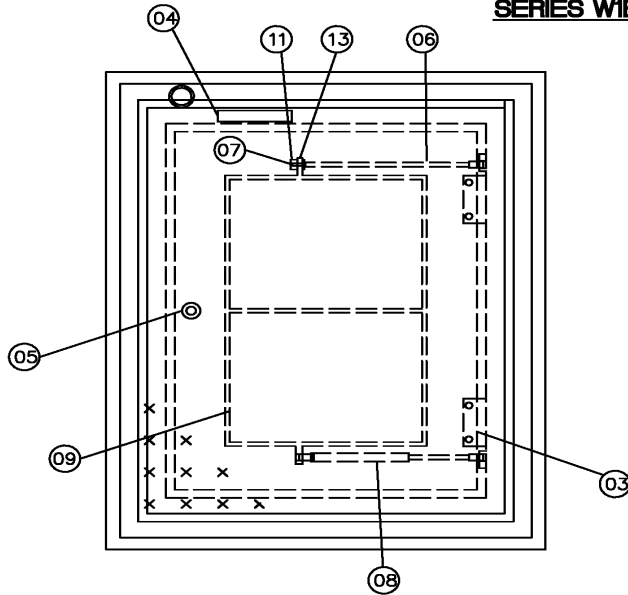

STANDARD COMPONENT PARTS

- ① FRAME EXTRUSION
- ② DIAMOND PLATE COVER
- ③ HINGES W/ HARDWARE
- ④ LIFTING HANDLE
- ⑤ SLAM LOCK
- ⑥ HOLD-OPEN ARM
- ⑦ POSITIVE LOCKING LATCH
- ⑧ SPRING ASSIST
- ⑨ COVER REINFORCEMENT
- ⑩ NEOPRENE GASKET
- ⑪ UPPER CLEVIS ASSEMBLY
- ⑫ LOWER CLEVIS ASSEMBLY
- ⑬ GUIDE PLATE
- ⑭ DRAIN COUPLING

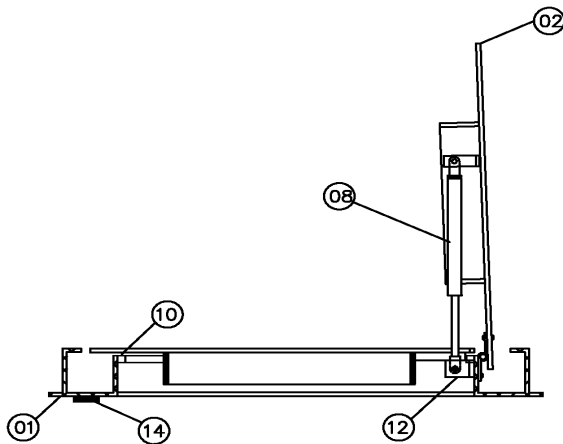

NOTE: Component Part Pricing:

Due to component part sizes and pricing change, Halliday Products Inc. does not list component part pricing. Halliday Products Inc. has a Limited Life Time Warranty on parts. See Warranty



SERIES WIB OPTIONS

- (A) LOCKING BAR
- (B) KEYED CYLINDER LOCK
- (C) RECESSED LOCK BOX
- (D) SLAB SKIRTING
- (E) SAFETY POST & CHAIN

- (F) SAFETY POST & CABLE
- (G) INSULATION
- (H) GASKET
- (I) BOLT DOWN
- (J) RETRO-GRATE

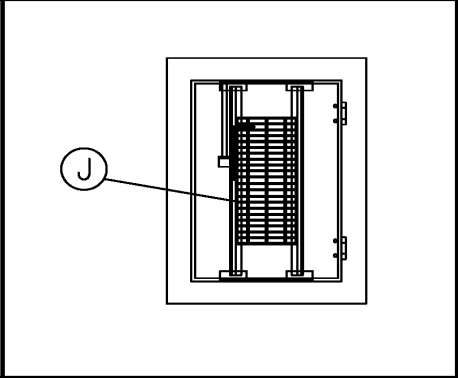
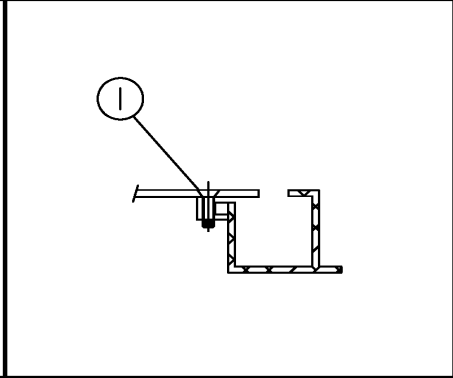
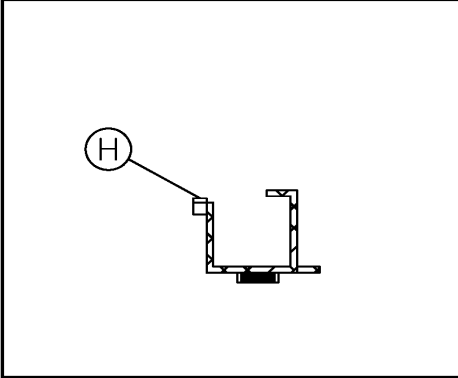
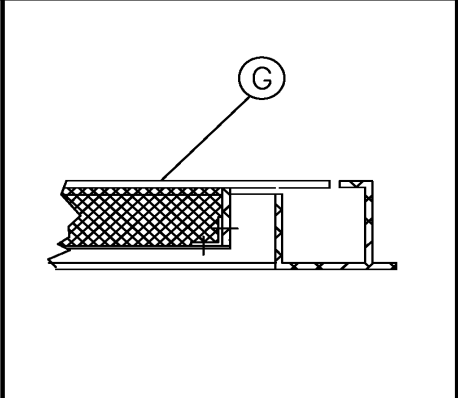
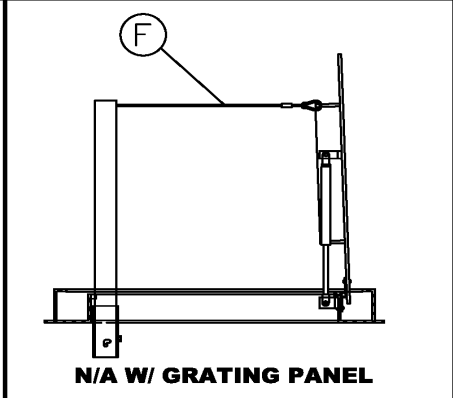
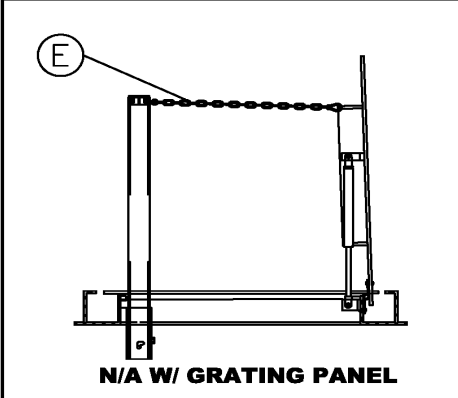
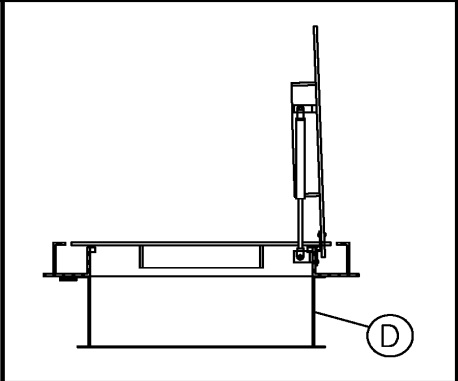
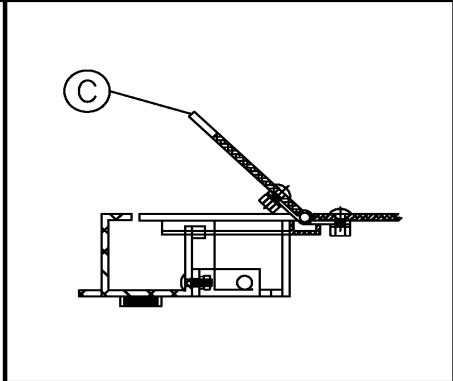
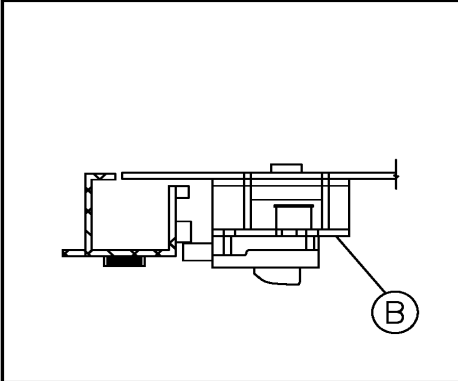
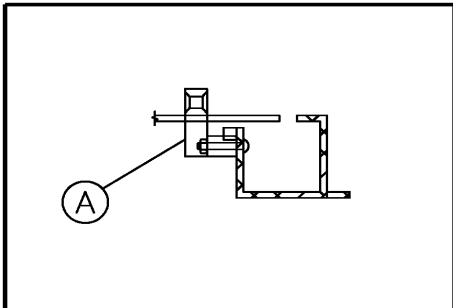



SERIES W2B

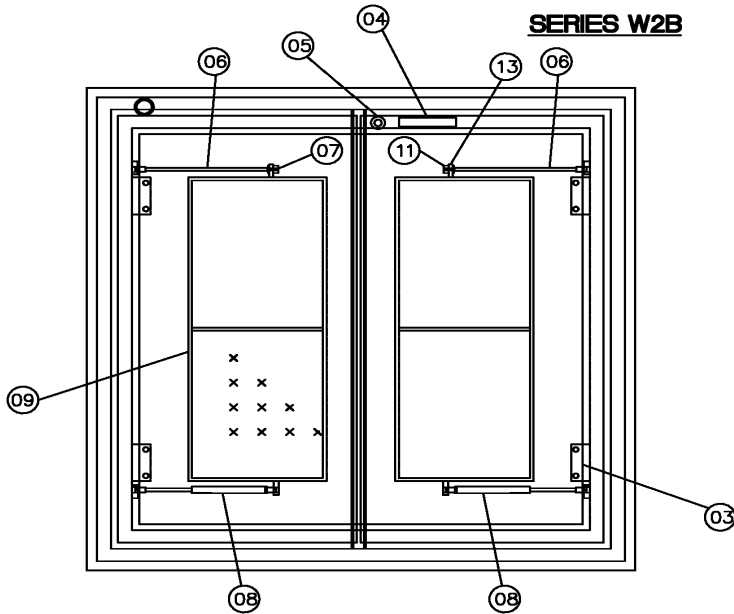

STANDARD COMPONENT PARTS

- ① FRAME EXTRUSION
- ② DIAMOND PLATE COVER
- ③ HINGES W/ HARDWARE
- ④ LIFTING HANDLE
- ⑤ SLAM LOCK
- ⑥ HOLD-OPEN ARM
- ⑦ POSITIVE LOCKING LATCH
- ⑧ SPRING ASSIST
- ⑨ COVER REINFORCEMENT
- ⑩ NEOPRENE GASKET
- ⑪ UPPER CLEVIS ASSEMBLY
- ⑫ LOWER CLEVIS ASSEMBLY
- ⑬ GUIDE PLATE
- ⑭ DRAIN COUPLING
- ⑮ EMBED TABS
- ⑯ ASTRIGAL

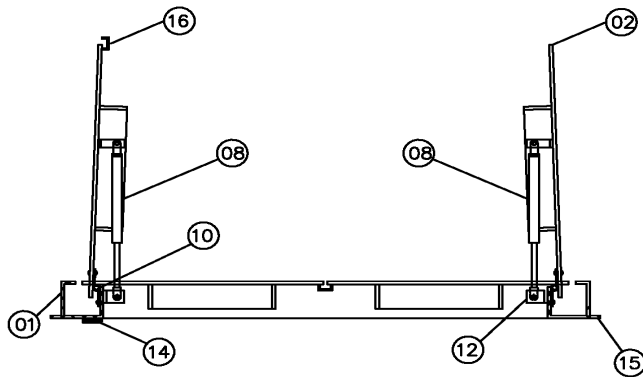

NOTE: Component Part Pricing:

Due to component part sizes and pricing change, Halliday Products Inc. does not list component part pricing. Halliday Products Inc. has a Limited Life Time Warranty on parts. See Warranty



SERIES W2B OPTIONS

- (A) LOCKING BAR
- (B) KEYED CYLINDER LOCK
- (C) RECESSED LOCK BOX
- (D) SLAB SKIRTING
- (E) SAFETY CABLE

- (F) SAFETY CHAIN
- (G) INSULATION
- (H) GASKET
- (I) BOLT DOWN
- (J) RETRO-GRATE

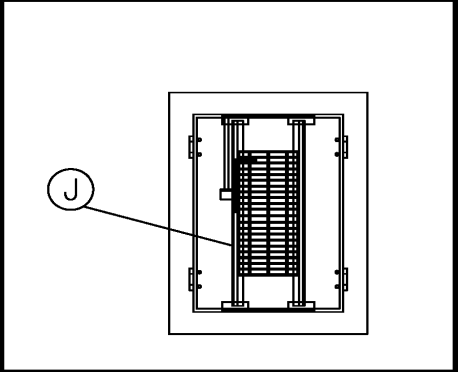
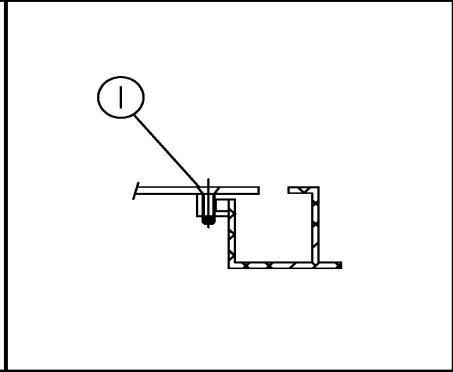
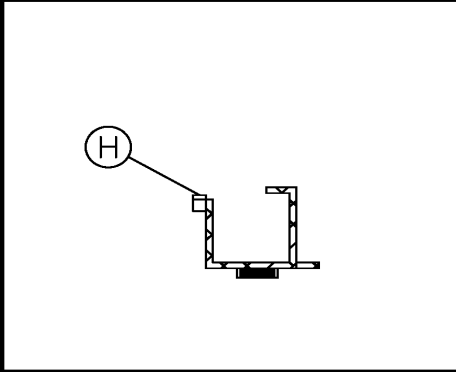
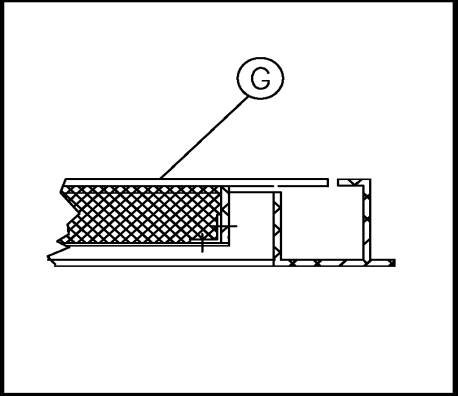
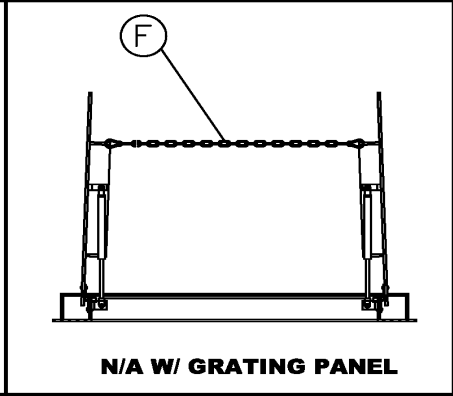
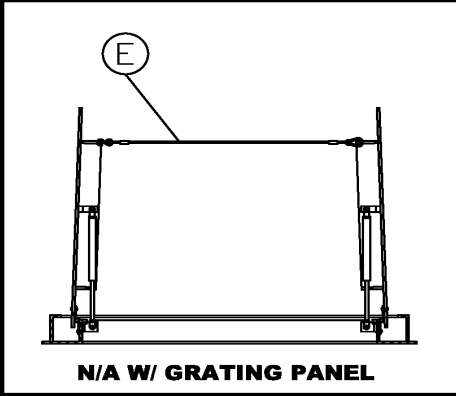
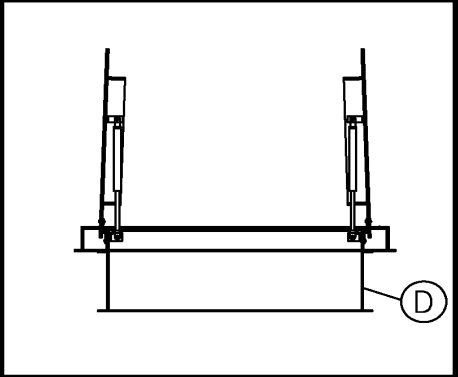
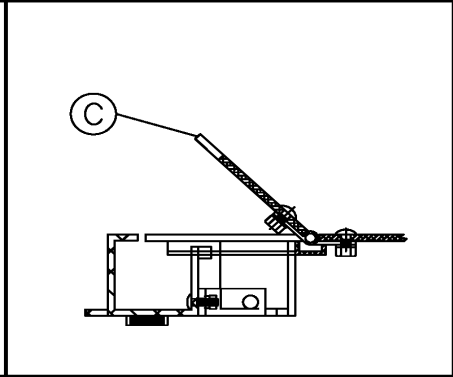
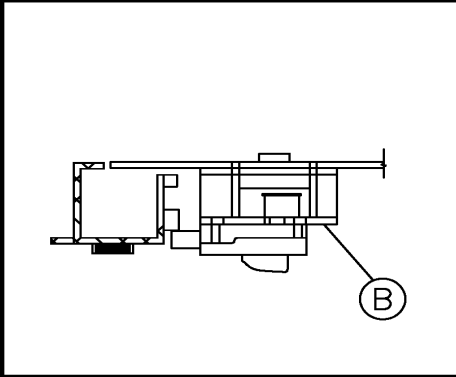
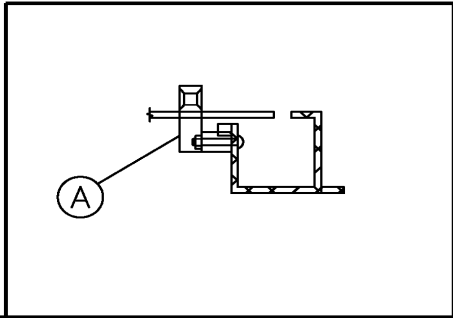

STORAGE, HANDLING, INSTALLATION and MAINTENANCE

STORAGE:

Prior to installation access covers should be stored in a dry area on the original shipping pallets.

HANDLING:

Standard practice precautions should be taken whenever handling or moving palletized access covers by forklift.

INSTALLATION:

For proper installation, Halliday Products, Inc. recommends the following:

1. Formwork must be flush to the inside of frame.
2. Secure unit to formwork using standard construction practices.
3. When pouring concrete, cover should be in the closed position.
4. Concrete to finish flush with top of unit framework.
5. Unit should be left in formwork for not less than 24 hours.
6. Clean all excess concrete from frame, over seat; in the case of a channel frame model, the drainage coupling.

MAINTENANCE:

Because access covers manufactured by Halliday Products, Inc. are of all aluminum and stainless steel construction, they require minimal maintenance. For optimum product life the manufacturer recommends the following procedures be performed annually:

1. Apply graphite to the interior of all locking devices.
2. Apply a light coating of machine oil to all hinges and hardware.
3. Remove all debris from the cover seat and around hinges.
4. Check and tighten any loose hardware.
5. In the case of a channel frame model, remove loose debris from channel.



LIMITED WARRANTY

Halliday Products, Inc., a Florida Corporation (“Company”) warrants to the original customer the stainless steel access frame and cover will be free from defective material or faulty workmanship for the life of the unit. In the event of malfunction or other indication of failure attributable directly to defective material or faulty workmanship, Company will, upon receipt of a written notification from customer of such defective material or faulty workmanship at its option and expense, repair or replace the defective frame and cover, or a component thereof, to whatever extent Company shall deem necessary to restore the frame and cover, or a component thereof, to proper operating condition. Company may replace the defective frame and cover, or a component thereof, with either a new or remanufactured, functionally equivalent frame and cover or component thereof at the Company’s option. **THIS WARRANTY IS EXCLUSIVE AND IN LIEU OF ALL OTHER WARRANTIES, WHETHER OR NOT STATUTORY, OR EXPRESSED OR IMPLIED, INCLUDING WITHOUT LIMITATION, THE IMPLIED WARRANTIES OF MERCHANTABILITY AND FITNESS FOR A PARTICULAR PURPOSE. THE EXCLUSIVE REMEDY FOR DEFECTIVE FRAME AND COVER SHALL BE ONLY IN CONTRACT, WHETHER OR NOT CAUSED BY A DEFECTIVE FRAME AND COVER, OR NEGLIGENCE. COMPANY’S LIABILITY FOR LOSS OR DAMAGES SHALL NOT EXCEED THE PRICE PAID BY CUSTOMER FOR THE FRAME AND COVER, REGARDLESS OF THE FORM OF ANY CLAIM. IN NO EVENT SHALL COMPANY BE LIABLE FOR ANY SPECIAL, INCIDENTAL, INDIRECT, CONSEQUENTIAL, OR PUNITIVE DAMAGES WHATSOEVER RESULTING FROM A DEFECTIVE FRAME AND COVER OR COMPONENT THEREOF. IF MODIFICATION OR ALTERATION IS MADE TO THE FRAME AND COVER OR COMPONENT THEREOF BY OTHER THAN COMPANY AUTHORIZED PERSONS, OR IF IT IS INSTALLED IMPROPERLY, OR MISUSED, ABUSED AND/OR NEGLECTED, THIS LIMITED WARRANTY IS NULL AND VOID AND OF NO EFFECT. THIS LIMITED WARRANTY DOES NOT APPLY AND THE COMPANY WILL HAVE NO RESPONSIBILITY HEREUNDER FOR NORMAL WEAR AND TEAR.**

Halliday Products, Inc.
6401 Edgewater Dr
Orlando, FL 32810
Toll Free: 800-298-1027
Fax: 407-298-4534
Email: Marketing@HallidayProducts.com