

SERIES BB TRASH BASKETS

TABLE OF CONTENTS

V e n d o r D a t a

A p p l i c a t i o n a n d S p e c i f i c a t i o n

I n s t a l l a t i o n a n d M a i n t e n a n c e I n s t r u c t i o n s

L i m i t e d W a r r a n t y

VENDOR DATA

**HALLIDAY PRODUCTS, INC.
6401 Edgewater Drive
Orlando, FL 32810**

Phone: 407-298-4470 - Fax: 407-298-4534

Toll Free: 800-298-1027

Email: info@HallidayProducts.com

Web Site at www.HallidayProducts.com

Armond Bordeau, Contact

BB Series Bar Screen Basket

APPLICATION:

Bar Screen style baskets are used to screen out solids that may otherwise damage pumping equipment in wet wells. This style basket is for heavy-duty applications, screening up to a 36 inch influent pipe. Standard baskets are manufactured of aluminum or stainless steel and are used in conjunction with a heavy-duty aluminum or stainless steel channel rail system. Units are supplied with solid aluminum or stainless steel wheels. Standard bar spacing for the front, back and bottom of the basket is 2 inches with other spacing available. The basket sides are solid but can be perforated if required. The standard rail system doubles as a ladder or can be manufactured as a guide rail system only if required. Trash baskets are used with portable hoists, which are used to raise and lower the basket for cleaning purposes.

SPECIFICATION:

B1B (Aluminum)
B4B (T304 Stainless Steel)
B6B (T316 Stainless Steel)

The basket systems, as manufactured by Halliday Products, Inc. of Orlando, Florida, shall be of the bar screen style basket, having 2" clear opening between ¼" thick bars and solid sides. The heavy duty ladder/guide rail system shall be of 3" structural channel and incorporate slip resistant rungs 12" on center. For ease of operation, the basket will have (4) 2-½" solid wheels with ½" stainless steel axles. A basket stop shall be supplied loose for field mounting to insure proper basket position.

HP
HALLIDAY PRODUCTS
SERIES B1B, B4B, B6B
(RUL AND BASKET SYSTEM)

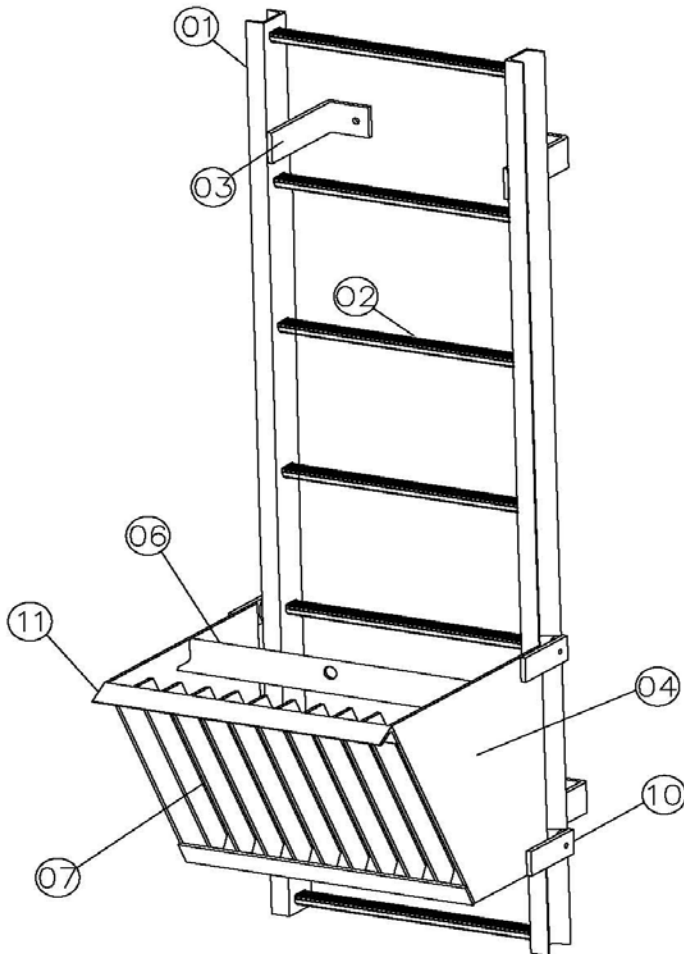

STANDARD COMPONENT PARTS

- ① CHANNEL RAIL
- ② LADDER RUNG
- ③ STANDOFF
- ④ BASKET SIDE PLATE
- ⑤ BASKET BACK PLATE
- ⑥ BAIL
- ⑦ BASKET FRONT BARS
- ⑧ BASKET BOTTOM BARS
- ⑨ WHEEL
- ⑩ WHEEL TABS
- ⑪ BASKET FRONT ANGLE

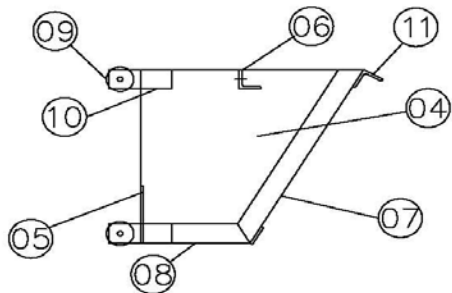

STANDARD BASKET

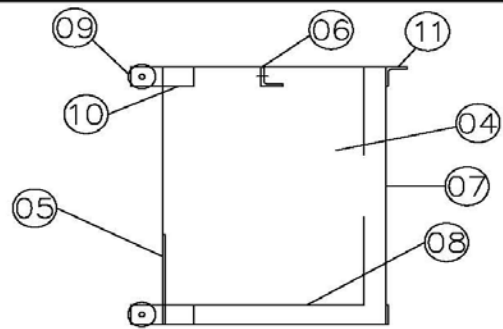

**SQUARE BASKET
(OPTIONAL)**

Installation and Maintenance

INSTALLATION:

For proper installation, Halliday Products, Inc. recommends the following:

1. Rail system must be set plumb and with rails straddling the influent pipe.
2. Rails must be secured to the tank wall at standoff locations with anchor bolts.
3. To insure optimum screening, the influent pipe should be located within 1-inch of the rail system. The basket stop should be placed approximately 12-inches below the invert.
4. Basket should be gently lowered into position. Never drop the basket into position.

MAINTENANCE:

Because Bar Screen baskets and rail systems manufactured by Halliday Products, Inc. are of all aluminum and stainless steel construction, they require minimal maintenance. For optimum product life the manufacturer recommends the following procedures be taken annually:

1. Check and tighten any loose anchor bolts and the basket stop attaching hardware.
2. Check and maintain hoisting cable connection.
3. Remove debris from basket and rails when required.



LIMITED WARRANTY

Halliday Products, Inc., a Florida Corporation (“Company”) warrants to the original customer the aluminum and stainless steel trash basket assemblies will be free from defective material or faulty workmanship for a period of three (3) years from date of purchase by Customer. In the event of malfunction or other indication of failure attributable directly to defective material or faulty workmanship, Company will, upon receipt of a written notification from customer of such defective material or faulty workmanship, at its option and expense, repair or replace the defective trash basket assembly, or a component thereof, to whatever extent Company shall deem necessary to restore the trash basket assembly, or a component thereof, to proper operating condition. Company may replace the defective trash basket assembly, or a component thereof, with either a new or remanufactured, functionally equivalent trash basket assembly or component thereof at the Company’s option. **THIS WARRANTY IS EXCLUSIVE AND IN LIEU OF ALL OTHER WARRANTIES, WHETHER OR NOT STATUTORY, OR EXPRESSED OR IMPLIED, INCLUDING WITHOUT LIMITATION, THE IMPLIED WARRANTIES OF MERCHANTABILITY AND FITNESS FOR A PARTICULAR PURPOSE. THE EXCLUSIVE REMEDY FOR DEFECTIVE TRASH BASKET ASSEMBLY SHALL BE ONLY IN CONTRACT, WHETHER OR NOT CAUSED BY A DEFECTIVE TRASH BASKET ASSEMBLY, OR NEGLIGENCE. COMPANY’S LIABILITY FOR LOSS OR DAMAGES SHALL NOT EXCEED THE PRICE PAID BY CUSTOMER FOR THE TRASH BASKET ASSEMBLY, REGARDLESS OF THE FORM OF ANY CLAIM. IN NO EVENT SHALL COMPANY BE LIABLE FOR ANY SPECIAL, INCIDENTAL, INDIRECT, CONSEQUENTIAL, OR PUNITIVE DAMAGES WHATSOEVER RESULTING FROM ANY DEFECTIVE TRASH BASKET ASSEMBLY OR COMPONENT THEREOF. IF MODIFICATION OR ALTERATION IS MADE TO THE TRASH BASKET ASSEMBLY OR COMPONENT THEREOF BY OTHER THAN COMPANY AUTHORIZED PERSONS, OR IF IT IS INSTALLED IMPROPERLY, OR MISUSED, ABUSED AND/OR NEGLECTED, THIS LIMITED WARRANTY IS NULL AND VOID AND OF NO EFFECT. THIS LIMITED WARRANTY DOES NOT APPLY AND THE COMPANY WILL HAVE NO RESPONSIBILITY HEREUNDER FOR NORMAL WEAR AND TEAR.**

Halliday Products, Inc.
6401 Edgewater Dr
Orlando, FL 32810
Toll Free: 800-298-1027
Fax: 407-298-4534
Email: Info@HallidayProducts.com